

PreView Sentry®79

The New 79GHz Front & Rear Detection Radar Solution

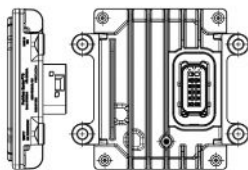
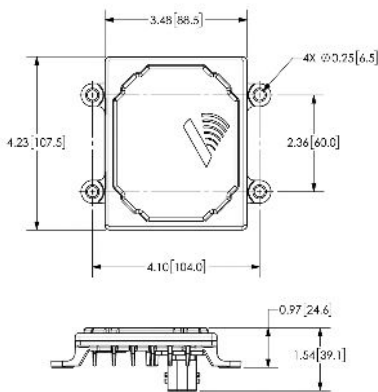

Description

Sensata's PreView Sentry®79 is an advanced 79 GHz front and rear detection radar sensor designed to enhance driver awareness and minimize the risk of blind spot related accidents. The sensor has a fully configurable detection zone, with the ability to detect objects at ranges up to 40 meters (131 feet). The width of the detection zone is adjustable to fit almost any vehicle type to keep operators and jobsites safer. With its high-precision radar technology, the PreView Sentry®79 provides drivers with real-time, reliable information about objects in their blind spots, significantly reducing the potential for collisions during take-off and backing maneuvers. It is the industry's most flexible, accurate, and powerful active blind spot monitoring solution available.

The expansion of Sensata's PreView® Radar product line is the result of over two decades of experience working with drivers, fleets, body builders, and OEMs to understand and deliver on requirements and preferences for radar-based collision mitigation solutions.

Features and Benefits

- 79 GHz FMCW
- Programmable range and width
- Detects, tracks, and reports the location of up to 64 people and objects simultaneously
- Detect objects from the face of the radar up to 50 meters (160 feet)
- UN Regulation No. 159 Moving Off Information System (MOIS) Compliant
- Environmentally hardened and robust (IP6K9K)

Applications

Heavy equipment, mining, civil, construction, road and utility equipment, forestry, agriculture

Tech Specs

Frequency Band	77-81 GHz Bandwidth, FMCW Waveform
Communication Interface	2x CAN 2.0b. J1939 250/500 Kbits/sec. (1 Mbps/sec. option)
Range	Configurable from 0.5-40 m
Range Resolution	0.2 m
Range Accuracy	±0.2 m
Vertical Field of View	±10 degrees
Horizontal Field of View	±75 degrees
Max Doppler Velocity	±14.3 m/s
Doppler Resolution	0.5 m/s
Doppler Accuracy	±0.2 m/s
Number of Raw Targets	Up to 64
Number of Target Tracks	Up to 64
Update Rate	50 ms
Input Power	9-33 V DC up to 600 mA max
Auxiliary Input/Auxiliary Output	9-33 V DC/9-33 V DC - Switch to Ground
Operating/Storage Temperature	-40° to +85° C/-55° to +105° C
System Diagnostics	Built in Self Test (BIST), Sensor Blockage Warning
Enclosure Temperature	IP6K9K
Connector Type	TE GET64, HDSCS 12 pin



Authorised Importer and Master Distributor

APS USA
sales@aps-supply.com
P: 1 619 263 4164

APS Australia
sales.apsa@aps-supply.com
P: 61 (8) 9302 2369 (WA)
P: 61 (02) 4915 6781 (NSW)

APS Colombia
ventascolombia@aps-supply.com
T: 57 (4) 444 7275

APS Chile
ventaschile@aps-supply.com
T: 56 (2) 2948 8044

APS Perú
ventasperu@aps-supply.com
T: 56 (2) 2948 8044

APS Indonesia
techcenter@aps-supply.com



APS Contact Page

PreView Sentry[®]79

What's The Difference Between 24GHz and 79GHz?

Sensor Specifications	PreView Sentry [®]	PreView Sentry [®] 79
Transmitter	24GHz Narrow Band	79GHz FMCW Waveform
Protection Rating	IP69K	IP6K9K
Dimensions	4.90" (w) x 4.06" (h) x 1. 8" (d)	4.65 in (w) x 4.23 in (h) x 1.54 in (d)
Weight	1.15 lb	0.5 lb
Configurable Range	0 – 30 m	0.2 – 40 m
Cycle Time	80 ms	50 ms
Target Detection Time	240 ms	150 ms
Mounting Location	Mounted center of vehicle	Can be mounted off center
Area of Interest	5 Zones. Can be adjusted to cover desired area in front or rear of vehicle	5 Zones. Can be adjusted asymmetrically to cover desired area in front or rear of vehicle. 2 configurable detection areas for equipment specific customization
Frequency	24.00 – 24.25 GHz	78.6 – 79.4 GHz (800 MHz)
Operating Conditions	Operates in all weather conditions	Operates in all weather conditions

Example Detection Zones



PreView Sentry[®]

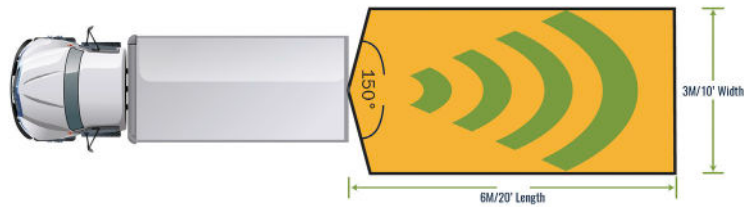

PreView Sentry[®]79

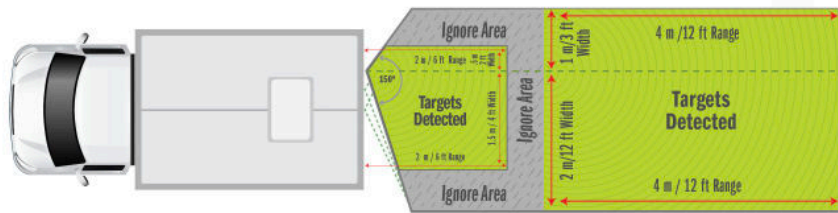

Multi-Sensor System Capabilities

Combining innovative technologies gives fleets one robust, intuitive safety system for a safer and more reliable vehicle. PreView Radar solutions integrate into all medium and heavy-duty vehicles and mobile equipment to assist operators and make roads and worksites safer and more efficient.

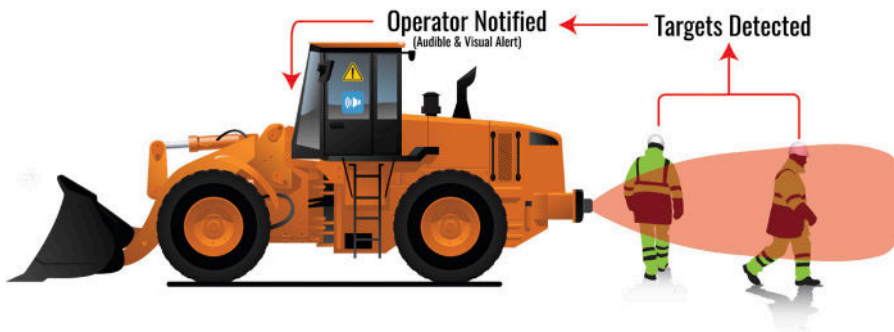
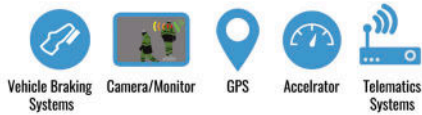

Authorised Importer and Master Distributor

APS USA
sales@aps-supply.com
P: 1 619 263 4164

APS Australia
sales.apsa@aps-supply.com
P: 61 (8) 9302 2369 (WA)
P: 61 (02) 4915 6781 (NSW)

APS Colombia
ventascolombia@aps-supply.com
T: 57 (4) 444 7275

APS Chile
ventaschile@aps-supply.com
T: 56 (2) 2948 8044

APS Perú
ventasperu@aps-supply.com
T: 56 (2) 2948 8044

APS Indonesia
techcenter@aps-supply.com



APS Contact Page