

ABL SHD 5000 LED Series Work Light



Description

Highly vibration-resistant high-output work light specifically designed to operate on tracked dozers, hydraulic excavators, and rock crushers.

Applications

Heavy equipment, construction, mining, support vehicles, agriculture, forestry

Tech Specs

Voltage	12-24V DC
Source	LED
Amperage	2A @ 24V DC
Wattage	48W
Lumens	5000 Lu
Connector	AMP 2 pin, DT 2 pin
Color Temperature	6000 K
Beam Pattern	Flood, Long Range, Wide Flood and Asymmetric Flood
Color	White
Mounting	Pedestal, suspended
IP Protection	IP68, IP69K
Polarity	Protected against reverse voltage
Electronic Thermal Management	Full output at +35°C ambient, 25 % dimmed at + 50°C ambient
Operating Temperature	-40°C to +85°C
Load Dump	36V Continuous / ISO 7637-2 Pulse 5a
Vibration Resistance	20 Grms, from 24Hz to 2000Hz
Salt Spray Test	ISO 9227
Shock Resistance	80G
EMC	ISO 13766 - ISO 14982 - ISO 12985 - CISPR25 Class 5
Warranty	5 Years

Part No.	Description
SHD5000LED-F	Flood, 5000Lu, 12-24V DC, 2A @ 24V DC, 48W
SHD5000LED-LR	Long Range, 5000Lu, 12-24V DC, 2A @ 24V DC, 48W
SHD5000LED-WF	Wide Flood, 5000Lu, 12-24V DC, 2A @ 24V DC, 48W
SHD5000LED-FA	Asymmetric Flood, 5000Lu, 12-24V DC, 2A @ 24V DC, 48W

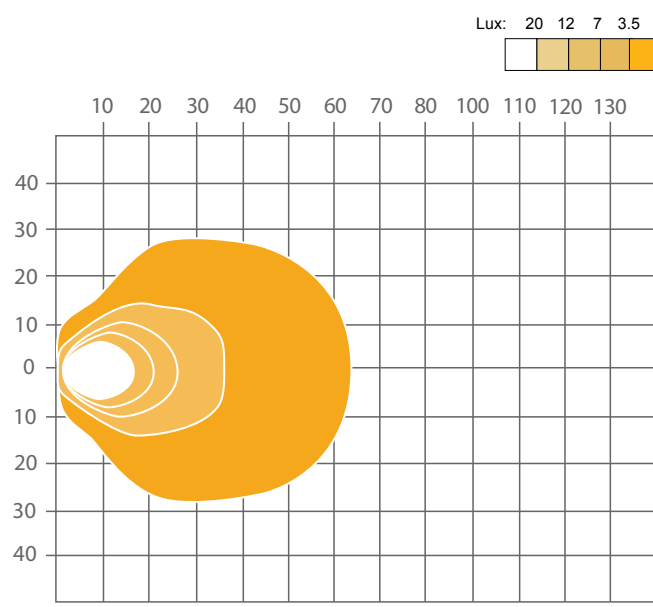
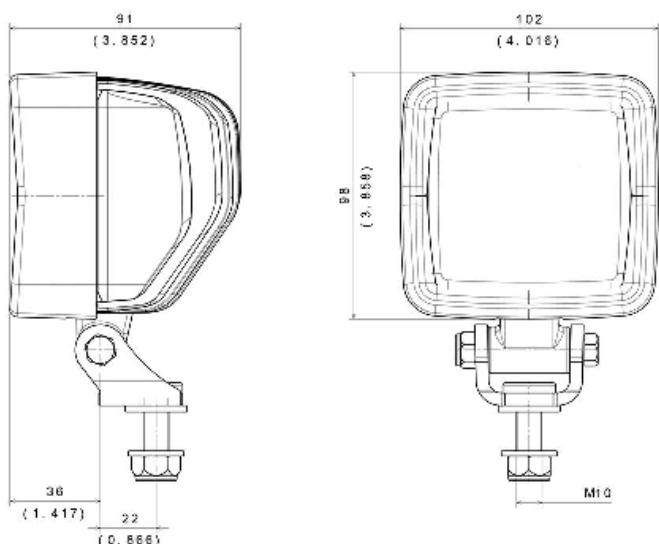

Authorised Importer and Master Distributor

