

Vision X Drift Strobe 3 LED Series

Designed With Enhanced Visibility

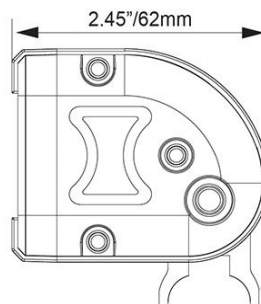
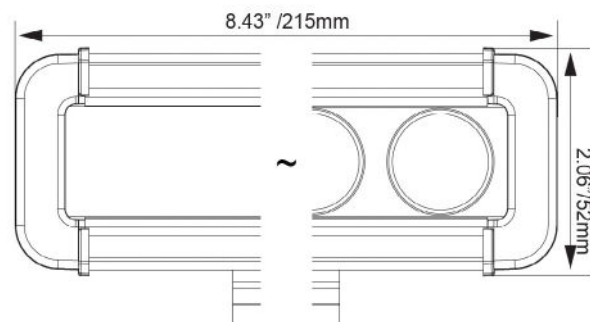

Description

The Drift Strobe Series is designed with enhanced visibility down narrow passageways. Necessary for placement on both the front and rear of the vehicle, the drift strobe is built with a focused beam to aim at the top of the drift notifying oncoming traffic up to 200 feet sooner than a conventional strobe without blinding either operator.

Features and Benefits

- Durable Die-Cast Housing Construction
- Four Colored LED Options
- Reverse Polarity Protection
- 15.6 Grms Vibration Rating

Tech Specs

Fixture Weight	2.62 lbs (1.19kg)
Shipping Weight	4.03 lbs (1.83kg)
Mounting	Dual M6 Stud Mount
LED	3W (CREE) XPE-2
Raw Lumens	Varies by Color
Wattage	9W
Wattage Per LED	3W
Amp Draw	0.6A @ 12V
Color Temperature	Varies by Color
Operating Voltage	9-32V DC
Operating Temperature	-40°C ~ 80°C
Lifespan	50,000 hrs
Polarity	Reverse Polarity Protection
Connector	2 Pin Deutsch
Housing	Die-Cast 6061 Aluminum
Finish	Gloss Black
Lens	Polycarbonate
EMC Emission	(CISPR 25) Edition 3.0 (2008-03) Class 3
Ingress Protection	IP-68
Vibration Rating	15.6 Grms
Warranty	3 Years

Part No.	Description
XIL-LP625R.2HZ	Red Beam Pattern, 9-32V DC, IP68
XIL-LP625G.2HZ	Green Beam Pattern, 9-32V DC, IP68
XIL-LP625B.2HZ	Blue Beam Pattern, 9-32V DC, IP68
XIL-LP625A.2HZ	Amber Beam Pattern, 9-32V DC, IP68



Authorised Importer and Master Distributor

