

ABL LED1000

Heavy-Duty Work Light

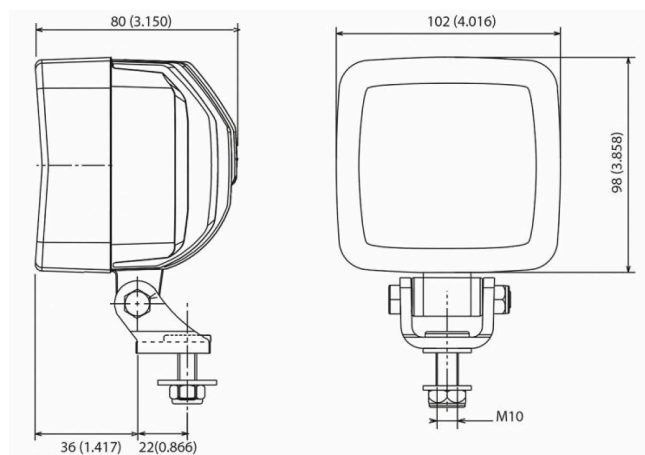

Description

The ABL LED1000 is a heavy-duty LED work light that outputs 1000 Lumens from only 14W of power. It's built tough with a hardened glass lens, IP68 and IP69K ingress protection, 60G shock and 15 Grms @ 24Hz-2000Hz vibration rating. It also features EMC CISPR25 class 5 certification making it suitable for heavy vehicles and machinery in mining and construction.

Application

Heavy equipment, mining, construction, road and utility equipment, forestry, agriculture

Tech Specs

| | |
|-------------------------------|---|
| Type | Heavy-duty LED work light |
| Voltage | 12-24V DC |
| Wattage | 14W |
| Current | 0.58A @ 24V DC |
| Lumens | 1000 Lu |
| Beam Pattern | Flood |
| Colour Temperature | 6000°K |
| IP Rating | IP68, IP69K |
| Shock Resistance | 60G |
| Vibration Resistance | 15 Grms @ 24-2000Hz |
| EMC | ISO 13766, ISO 14982, ISO 12985, CISPR25 Class 5 |
| Operation Temperatures | -40°C to +85°C |
| Electronic Thermal Management | Full output at +35°C ambient, 20% dimmed at +50°C ambient |
| Load Dump / Surge Dump | Surge: 36V continuous / ISO 7637-2 Pulse 5a |
| Polarity | Protected against reverse voltage |
| Salt Spray Test | ISO 9227 |
| Connector | DT 2 pin |
| Mounting | Pedestal, suspended |
| Lens Material | Hardened glass |
| Electronic Thermal Management | Full output at +35°C ambient, 20% dimmed at +50°C ambient |
| Lens Material | Hardened glass |
| Lens Material | Hardened glass |
| Dimensions (DxWxH) | 3.15x4.0x3.86" inches (80x102x98mm) |
| Weight | 1.98 lbs (0.9kg) |
| Warranty | 30,000 operating hours or 5 years |

Beam Pattern

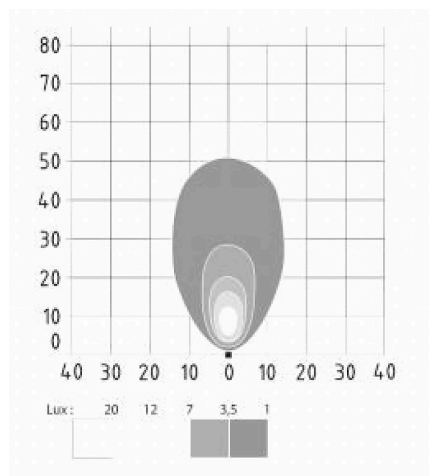

Flood

| Part No. | Description |
|----------|--|
| LED1000F | Flood, 1000 Lu, 12-24V DC, 0.58A @ 24V DC, 14W |



Authorised Importer and Master Distributor

