

J.W. Speaker Model 560 Series

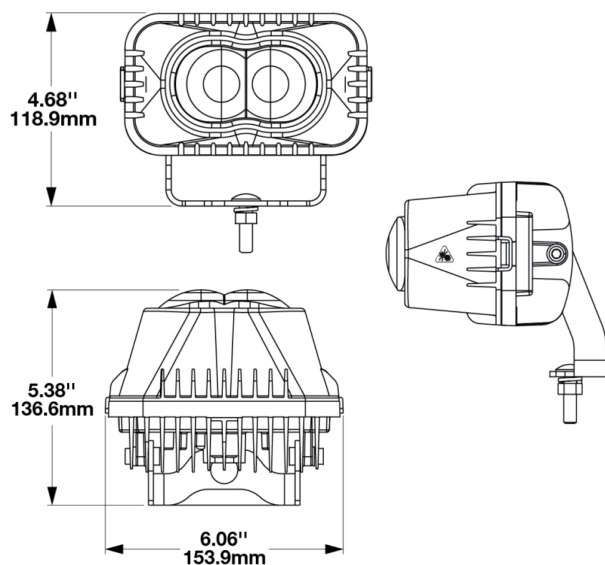

Warning Projector Light



Description

Maintaining workers' and pedestrians' safety while keeping other vehicles at a safe distance can be a challenge on worksites and in warehouses. Time and time again, vehicle lighting has been a major solution to the perils of hazardous work environments. With superior intensity and light quality, the innovative Model 560 LED Warning Projection Light plays an essential role in protecting operators and pedestrians from the potential dangers of moving machinery. As a result, occupational safety plus operator comfort and convenience are significantly improved, preventing workplace accidents.

Optional Flashing Sequence

All Model 560 versions come with a variety of beam sequences. Opt for the steady stay on beam pattern, or for additional eye-catching visibility, use the various flash modes to alert workers and pedestrians of dangerous areas. View Specification Sheets below for Flash Modes.

Mounting Pattern

The brightness (Lux) and pattern size will vary based on the mounting height.

Features

- 12-72V, suitable for various types of applications
- UL Recognized
- ECE Compliant
- IP67, IP69K, & CE Compliant
- Pedestal mount for vehicles or stationary objects

Applications

Construction, industrial and material handling

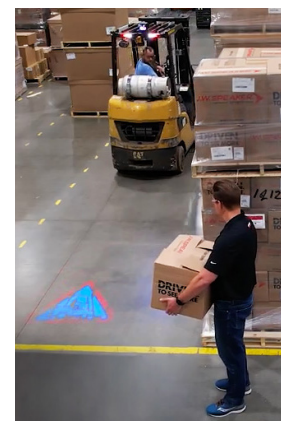

Tech Specs

Voltage	12-72V DC
Current Draw	3.6A @ 12V DC (Mode 0)
Beam Patterns	Warning - Flashing Warning Warning - Keep Out Zone
IP Rating	IP67, IP69K
Certifications	ECE, CE, UL Recognized
Outer Lens Material	Acrylic
Outer Lens Color	Clear
Housing Material	Aluminum
Housing Color	Black
Bezel Color	Black
Mounting Hardware	Single Carriage Bolt
Mounting Type	Adjustable Mount
Mating Connector	PE 12110293
Weight	1.72 lbs / 0.78 kgs
Dimensions (DxWxH)	5.38x6.06x4.68" (136.6x154x119mm)

Part No.	Description
560-FP	J.W. Speaker Model 560 Series, 12-72V LED Warning Projector Light
560-UP	J.W. Speaker Model 560 Series, 12-72V LED Universal Warning Projector Light



560-FP (Forklift Projector)

A bright blue forklift image is enclosed within a clear, distinct red triangle to warn workers in material handling areas that forklifts are nearby. The Model 560 lights can be placed atop a forklift and display a projection several feet away to create a safe zone for workers, including other drivers.



560-UP (Universal Projector)

A large, bright red exclamation point in a red triangle signals that danger is ahead. Workers and passersby can see the unmistakable warning projection clearly from many feet away — and steer clear of the area.

Authorised Importer and Master Distributor

