

# ECCO 6550 / 6570 Series

## SAE Class II Strobes



### Description

ECCO's 6500 Series strobe light offers outstanding value when a cost-effective SAE Class II light is required. Featuring a shock-resistant five-point power supply mounting and robust reinforced polypropylene base, this series of lights are suitable for both on- or off-highway applications. Thread-on polycarbonate lens and snap-fit flashtube allow easy field service without tools. Model-specific options include double or quad flash patterns.

### Features and Benefits

- Robust reinforced polypropylene base
- Thread-on polycarbonate lens and snap-fit flashtube allows easy field service
- Shock-resistant circuit board mounting incorporates 5 support points
- Consistent operation during voltage and temperature changes

### Tech Specs

Voltage	12-48V DC or 12-24V DC
Amps	2.4A @ 12-48V DC or 2.4A @ 12-24V DC
FPM	80 x2 or 65 x4
Mount	3 Bolt/1" Pipe Mount, Vacuum-Magnet Mount or Semi-Permanent HBT Mount
Profile	Low (6550A, 6550A-VM, 6550A-HBT) Medium (6570A, 6570A-VM, 6570A-HBT)
Colors Available	Amber, Blue, Clear, Green or Red
Temperature Range	-22°F to +122°F (-30°C to +50°C)
Standards Compliance	SAE Class II, CE, R10
Warranty	Strobe: 2 Years, Flashtube: 6 Months



**ECCO 6550A**



**ECCO 6570A**

Part No.	Description
6550A	Low Profile, 12-48V DC, 2.4A @ 12-48V DC, 80 x2 or 65 x4 FPM, 3 Bolt Flange / 1" Pipe Mount
6550A-VM	Low Profile, 12-24V DC, 2.4A @ 12-24V DC, 80 x2 FPM, Vacuum Magnet Mount
6550A-HBT	Low Profile, 12-24V DC, 2.4A @ 12-24V DC, 80 x2 FPM, Semi-Permanent HBT Mount
6570A	Medium Profile, 12-48V DC, 2.4A @ 12-48V DC, 80 x2 or 65 x4 FPM, 3 Bolt Flange / 1" Pipe Mount
6570A-VM	Medium Profile, 12-24V DC, 2.4A @ 12-24V DC, 80 x2 FPM, Vacuum Magnet Mount
6570A-HBT	Medium Profile, 12-24V DC, 2.4A @ 12-24V DC, 80 x2 FPM, Semi-Permanent HBT Mount



**ECCO 6550A-VM**



**ECCO 6550A-HBT**

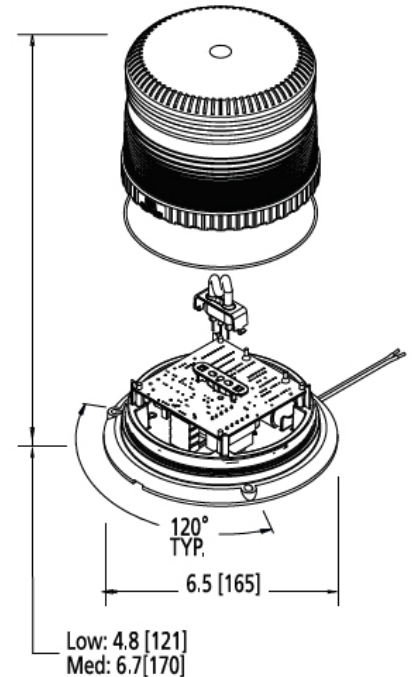

Authorised Importer and Master Distributor

