

J.W. Speaker 210 Series



LED Solar Red or Amber Flasher & Warning Light



Description

J.W. Speaker solar marker lights are engineered for optimal visibility under the most adverse conditions, including rain, dust, and vibrations. Unlike roadway markers which project light from the sides, our solar marker lights projects light perpendicular to the lamp, so it's easy to spot from further away.

No power? No problem. Provide warning indication of equipment, hazards or traffic changes by putting lights anywhere - even if no power is available or on. The J.W. Speaker solar marker lights are bright, easy-to-mount solar LEDs designed to make obstructions and hazards clearly visible, even from extended distances. The robust impact-modified acrylic housing withstands the harshest conditions, making it the ideal LED light for a wide range of dimly lit applications where power sources are unavailable.

Features and Benefits

- Up to 11 Candela brightness
- Visibility of up to 1 mile
- Perpendicular light beam offers easier identification from further distances
- ClickBond™ adhesive mount eliminates drilling and risking the structural integrity
- Rugged Housing is IP67, and IP69k rated for the harshest environments
- Available in amber or red to accommodate multiple applications
- Clean, reusable energy LED is maintenance-free
- Fully Charged in 6 hours, lasts for 172 hours
- 1 Year Warranty

Applications

Railways, Mining equipment, boat piers, and waterways, transportation vehicles, and construction vehicles.

Tech Specs

Colours	Red or Amber
Beam Pattern	Warning - Flashing Warning
Battery Run Time	172 hours
Battery Recharge Time	6 hours
Compliances	IP67, IP69K
Minimum Operating Temperature	-40 °C / -40 °F
Maximum Operating Temperature	65 °C / 149 °F
Outer Lens Material	Impact-modified Acrylic
Outer Lens Color	Clear
Housing Color	Black
Dimensions (WxHxD)	5.79x5.35x1.22" (147.1x136x21mm)
Shipping Weight	0.50 lbs / 0.23 kgs

Part No.	Description
SPE-210AF	Model 210 - LED Solar Amber Flasher and Warning Light (0647031)
SPE-210RF	Model 210 - LED Solar Red Flasher and Warning Light (0647041)

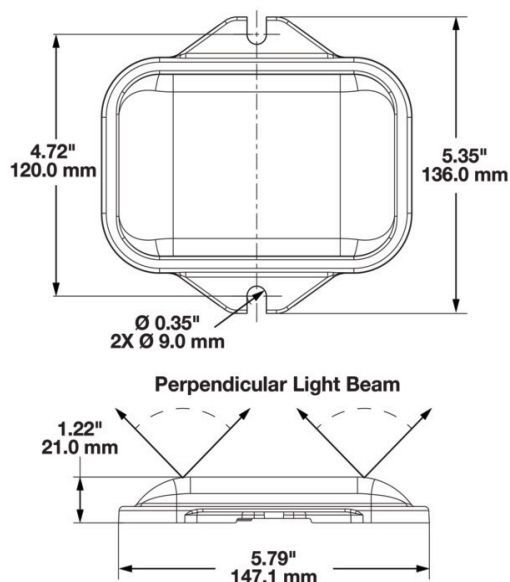

Fast, Durable Mounting and Installation

Mount J.W. Speaker solar marker lights quickly and securely to any surface without drilling. The powerful Click Bond adhesive-bonded mount is the optimal installation solution – quick and reliable. No drilling. No structural damage. No problem.

Heavy Duty Construction

The low-profile impact-modified acrylic lens is nearly indestructible and won't show signs of UV discoloration or degradation - even when used on rugged jobs sites with direct exposure to the harshest environments. Each light assembly is IP67 and IP69K rated, so they can be cleaned with ease using powerful high-pressure washers.



Authorised Importer and Master Distributor



J.W. Speaker 210 Series



APPLICATIONS



RAILWAY

Use powerful Click Bond™ installation mounting to place J.W. Speaker solar marker LED lights on wagons and rail cars to increase visibility and avoid catastrophic collisions in your railyard. The lights can also be placed at crossings to alert motorists of approaching trains. The lights emit a perpendicular light, which can be seen clearly by up to one mile by oncoming traffic.



BOAT PIERS & WATERWAYS

J.W. Speaker solar marker LED lights can be used on docks, piers, buoys and other objects to make them visible far off shore. The maintenance-free, fully sustainable lights are IP67 rated, so they can be immersed in water without degrading performance.



MINING

Tough jobsites and remote locations are no match for J.W. Speaker solar marker LED lights. These LEDs provide hours of light to clearly mark water pumps, generators, rock crushers and other obstacles in settings where electricity is the only thing more scarce than a break in the action.

CONSTRUCTION

Help crews identify heavy equipment, dangerous machines and hazardous conditions at any time with J.W. Speaker solar marker LED lights. Mount them using powerful Click Bond™ adhesive on excavators, storage units, trailers and more, so crews can feel safer and stay on schedule and avoid costly accidents.



ROAD SIGNAGE & RAILROAD CROSSING

J.W. Speaker solar marker lights can be attached to virtually any object, anywhere to alert motorists of hazards. The LEDs emit light perpendicular to the lamp, so approaching drivers can clearly see the precise places to avoid. It's ideal in places where power sources are limited and visibility is critical.



TRANSPORT

Long-haul truckers limited by stricter DOT hours of service spend more time at rest stops, truck yards, depots or even the side of the road waiting for their next shift to start. J.W. Speaker solar marker LED lights can be used to mark their presence while parked using renewable, solar-powered energy sources instead of draining electricity from the truck and trailer.

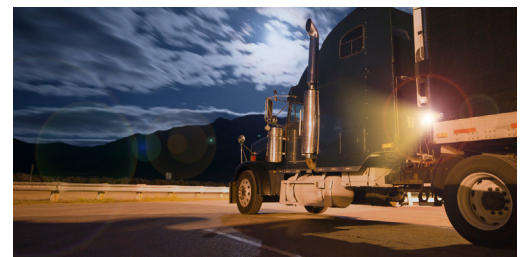

Authorised Importer and Master Distributor

