

# Vision X VL-Series 3 LED Light

## Light Duty Commercial

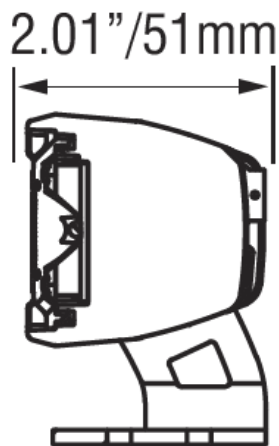
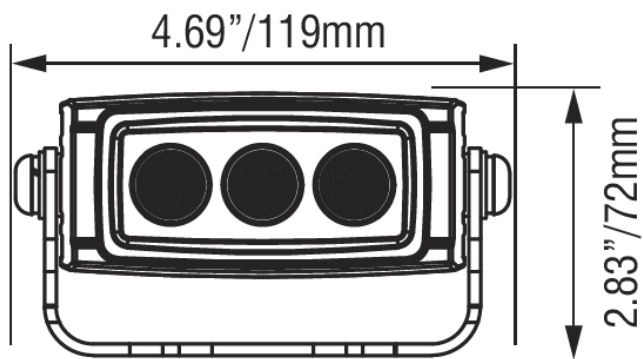

### Description

The VL Series LED Light offers outstanding light output in a functional design that adjusts with the single bolt bracket. High-quality construction and components enable the VL-Series LED Light Duty to withstand vibration up to 21 Grms. Built-in reverse polarity protection helps prevent accidental damage caused by incorrect installation. A high-value light, this series is designed for many light-duty commercial applications.

### Features and Benefits

- 5W CREE LEDs
- 9-32 Volts
- CISPR 25 Class 3
- Reverse Polarity Protection

### Tech Specs

Fixture Weight	1.1lbs (0.5kg)
Connector	None or Deutsch DT04-2P
Mounting	Single Bolt
LED	5W Cree
rLumens	1140 lm
eLumens	797 lm
Wattage	15W
Amp Draw	1.25A @ 12V
Color Temperature	6000K
Operating Voltage	9-32V DC
Operating Temperature	-40°C ~ 60°C
Lifespan	50,000hrs
Polarity	Reverse Polarity Protection
Housing Material	Aluminum
Lens	Polycarbonate
Finish	Powder Coated Gloss
EMC Emission	Compliance to EN55022, EN61000-3-2, Class A, EN61000-3-3
EMC Immunity	Compliance to EN55024, EN61000-4-2,3,4,5,6,8,11; light industry level (surge 2KV), criteria A
Ingress Protection	IP68, IP69K
Vibration Rating	21Grms
Warranty	1 Year

Part No.	Mount
VW0503M	Powder-coated, Deutsch Connector included
VL0503M	Powder-coated, Deutsch Connector not included
MAR-VW0503M	Stainless Steel, Deutsch Connector included
MAR-VL0503M	Stainless Steel, Deutsch Connector not included

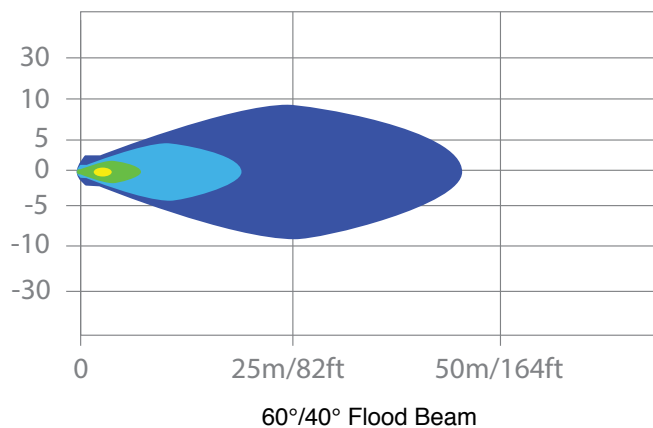

Authorised Importer and Master Distributor

