

ECCO 400 Series

Grommet Mount Back-up Alarm

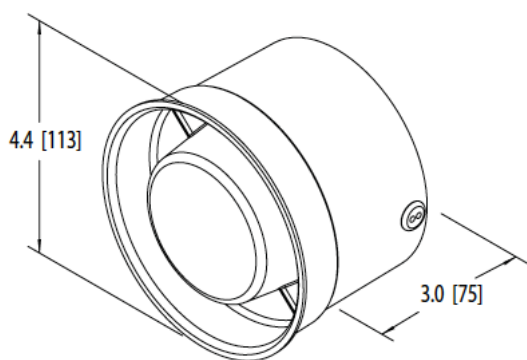

Description

The 400 Series back-up alarm features a reverse-mounted speaker design and utilizes a standard 4.5" rear lighting grommet for mounting directly into the vehicle body. Vehicle downtime is reduced as the alarm can be fitted or replaced quickly and easily without tools, there are no holes to drill and no bolts to tighten. Not only is the 'in-body' mounting method easier to install, but it also ensures the warning signal is projected where it is needed, directly into the hazard zone at the rear of the vehicle. Two models are available: 112dB(A) fixed decibel versions as well as an 87-112dB(A) Smart Alarm® unit.

Features and Benefits

- 87-112dB for the Smart Alarm model SA940, and 112dB for the 450 model
- Grommet mount reduces installation time and directs warning to rear of vehicle
- For use with standard 4.5" rear-lighting grommet (order separately)
- Epoxy sealed for protection against dust, moisture and vibration
- Temperature Range: -40°F to +185°F (-40°C to +85°C)

Tech Specs

Type	Smart Alarm (SA940), Fixed dB Alarm (450)
Voltage	12-24V DC (SA940), 12-36V DC (450)
Loudness (Db)	87-112dB (SA940), 112dB (450)
Amps (12V)	0.6A (SA940), 0.4A (450)
Approvals	CE, R10 (SA940), SAE Type A, CE, R10 (450)
Connection	16 AWG blunt cut wires
Housing	Fiberglass reinforced nylon
Mounting	4.5" standard rear lighting grommet
Warranty	ECCO LIFE
Dimensions (WxD)	4.4" x 2.8" inches (111.76 x 71.12mm)

Part No.	Description
SA940	Smart Backup Alarm, 12-24V DC, 87-112dB, 0.6A, CE, R10
450	Backup Alarm, 12-36V DC, 112dB, 0.4A, SAE Type A, CE, R10
R2140GR	Mounting Grommet



Authorised Importer and Master Distributor

