

ECCO EW2015

LED Pedestrian Boundary Light

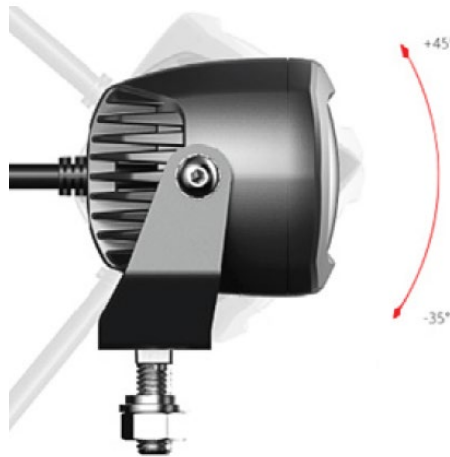

Description

ECCO's EW2015 LED Pedestrian Boundary Spotlights are designed specifically for material handling applications to provide a visual warning for pedestrians in the vicinity of mobile equipment. These lights are intended as a supplemental safety device in addition to a 360° warning light and project a bright red line onto the ground to the side of the vehicle. This additional safety feature is especially useful to warn pedestrians to stay clear of the equipment's turning circle, and is likely to be seen by pedestrians that are not looking up or paying close attention to their surroundings. Featuring 12-80 VDC operation, die-cast alloy housing, and a virtually unbreakable polycarbonate lens, the EW2015 is extremely resistant to impact and vibration damage.

Features and Benefits

- Three 3-watt LEDs
- Red boundary line projection
- Pedestrian warning for material handling applications
- Die-cast alloy heatsink housing
- Polycarbonate lens

Voltage	12-80V DC
Amps	0.6A
Color LED	Red
Standard Compliances	R10
Warranty	3 years

Part No.	Description
EW2015R	ECCO EW2015 LED Pedestrian Boundary Light: Red, 12-80V DC, 0.6A

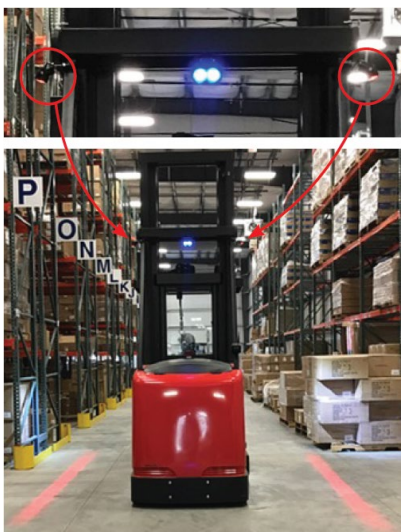

Authorised Importer and Master Distributor

