

ECCO 800 Series Surface Mount Alarm



Description

Surface Mount Alarms

Designed to meet all the harsh operational requirements of any fleets equipment, ECCO's 800 Series alarms feature steel housing and rugged construction for demanding applications. Reverse mounted speaker enhances sound and protects the alarm from dust and moisture ingress. Sealed in epoxy for protection against dust, moisture and vibration.

Features and Benefits

- Reverse mounted speaker enhances sound & protects the speaker from dust and moisture ingress
- Reinforced nylon housing eliminates corrosion damage
- Sealed in epoxy for protection against dust, moisture and vibration
- Steam cleanable and pressure washable
- Temperature Range: -40°F to +185°F (-40°C to +85°C)

Tech Specs

| | |
|--------------------|-----------------------------------|
| Voltage | 12-36V DC |
| Amps | 1.3A |
| Decibels | 112Db |
| Connection | 16 AWG blunt cut wires |
| Approvals | SAE Type A, CE, R10, UL, AMECA |
| Dimensions (WxHxD) | 5.7x4.2x3.1 inches (146x105x79mm) |

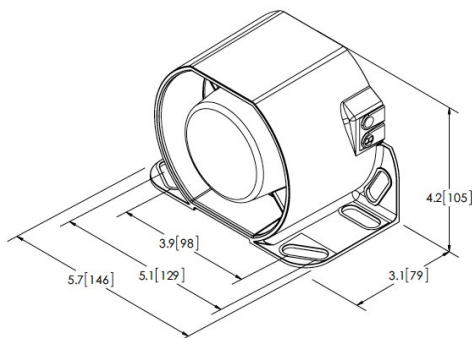

| Part No. | Description |
|----------|-------------------------------|
| 850N | ECCO 850N Surface Mount Alarm |



Authorised Importer and Master Distributor

