

# ABL500 LED1200

## 500 Series, 1200 Lu, 20W work lamp



### Description

ABL LED1200 in the 500 Series is a multi-volt (12-24V | 12-80V | 24V only) LED work lamp offering a direct substitution for your 12V 55W & 24V 70W Halogen, and 35W HID. It is equipped with a patented LED-engine holding high performance LEDs.

### Features and Benefits

- Patented LED-engine holding high performance LEDs
- 5 LEDs producing 1200 Lu from 20W
- Patented cooling system
- IP68, IP69K rating
- 15Grms @ 24-2000Hz Vibration and 60G Shock rating
- Available in Flood, Long-Range, and Amber Flood

### Applications

Material handling, heavy equipment, mining, construction, agriculture, forestry, utility vehicles, marine

### Tech Specs

Bulb	5 LED - 1200 Lumen
Lifetime	20 000 hours
Color Temperature	6000K
Light Pattern	Flood, Long Range
Consumption	20W
Voltage	Multi 12-100V
Intensity	0.82 Amp @ 24V
Weight	0.9 KG
Vibration Resistance	15 Grms from 24 to 2000Hz
Shock Resistance	60G
EMC	ISO 13 766 - ISO 14 982 - ISO 12 895
Load Dump	130V Continuous 200V 100ms 1800V 50µs
Polarity	No polarity
Electronic Thermal Management	Full output @ +35°C ambient 20% dimmed @ +50°C ambient
Water Tightness	IP 68 - IP 69K
Operating Temp	-40°C to +85°C
Salt Spray	ISO 9227
Lens	Hardened glass
Reflector	Multi lens system
Warranty	5 Years

Part No.	Beam	Voltage	Watts
LED1200AF-1280	Amber Flood	12-100V DC multi	20W
LED1200LR-1280	Long Range	12-100V DC multi	20W
LED1200F-1280	Flood	12-100V DC multi	20W

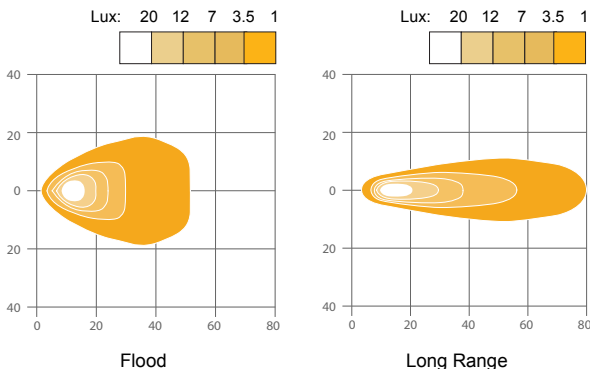
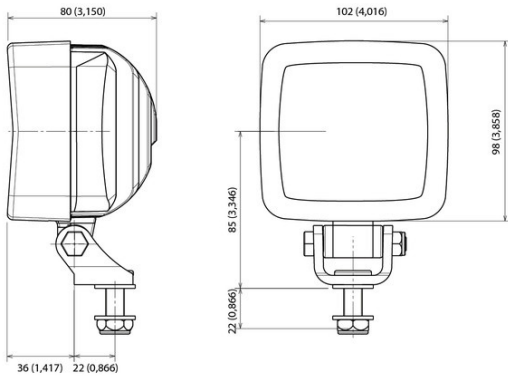

Authorised Importer and Master Distributor

