

PRECOTM
ELECTRONICS



PreView[®] Side DefenderTM
SDR8503 & SDL8503
System Operating Manual



Contents

Overview 1

- Product Description 1
- Other Sensor Features..... 2
- In-cab LED Display 2
- Sensor Interfaces and Configuration 3
- System Connections 3
- System Operation..... 3
- Technical Data..... 4
- Sensor Connector Description 4

Regulatory Compliance 5

Installation 6

- Sensor Mounting..... 6
- Mounting Tolerances 6
- Keep Out/Interference Zones 6
- Sensor Mounting Procedure..... 7

Initial System Power Up and Test..... 8

Troubleshooting..... 9

Object Detection Capability..... 10

- Notes on Safety and Risks 10
- Owner Responsibilities 10

PreView® Side Defender™ Daily Maintenance 11

Warranty Information 12

Tables

Table 1. Operator Display Description..... 2

Figures

- Figure 1. PreView® Side Defender™ Radar Sensor 1
- Figure 2. Horizontal Detection Zone 2
- Figure 3. In-cab LED Display Unit..... 2
- Figure 4. Wiring Connections..... 3
- Figure 5. PreView® Side Defender™ Radar Dimensions 4
- Figure 6. Deutsch Connector Pin Out..... 4
- Figure 7. Sensor Specifications..... 4
- Figure 8. Sensor Position on Vehicle 6
- Figure 9. Vertical and Horizontal Angle Mounting Tolerances 6
- Figure 10. Keep Out Zones 7
- Figure 11. Object Reflection 10



FCC STATEMENT

This device complies with Part 15 of the FCC Rules. Operation is subject to the following two conditions: (1) this device may not cause harmful interference, and (2) this device must accept any interference received, including interference that may cause undesired operation.

Warning: Changes or modifications to this unit not expressly approved by the party responsible for compliance could void the user's authority to operate the equipment.

NOTE: This equipment has been tested and found to comply with the limits of a Class B digital device, pursuant to Part 15 of the FCC Rules. These limits are designed to provide reasonable protection against harmful interference in a residential installation. This equipment generates, uses, and can radiate radio frequency energy and, if not installed and used in accordance with the instructions, may cause harmful interference to radio communications. However, there is no guarantee that interference will not occur in a particular installation. If this equipment does cause harmful interference to radio or television reception, which can be determined by turning the equipment off and on, the user is encouraged to try and correct the interference.

INDUSTRY CANADA STATEMENT

Per RSS-Gen, Section 8.4 This device complies with Industry Canada license-exempt RSS standard(s). Operation is subject to the following two conditions: (1) this device may not cause interference, and (2) this device must accept any interference, including interference that may cause undesired operation of the device.

Par RSS - Gen, Section 8.4 Cet appareil est conforme à Industrie Canada exempts de licence standards RSS. Le fonctionnement est soumis aux deux conditions suivantes : (1) ce dispositif ne peut pas provoquer d'interférences et (2) cet appareil doit accepter toute interférence , y compris les interférences qui peuvent causer un mauvais fonctionnement de l'appareil.

TRADEMARKS

The names of actual companies and products mentioned herein may be the trademarks of their respective owners. Any rights not expressly granted herein are reserved.

Patent pending.



OVERVIEW

This document describes the PreView® Side Defender™ radar system manufactured by PRECO® Electronics, located in Boise, Idaho, USA. There are two different systems described in this manual, the right (passenger) side system, model SDR8503 and the left side system, model SDL8503. This document covers the components that comprise the Side Defender™ radar systems – the Side Defender™ radar sensor, the PreView® in-cab display and the sensor/display interconnect cable. This document may be amended, corrected, and enhanced in keeping with the sensor development progress.



Figure 1. PreView® Side Defender™ Radar Sensor

Product Description

The PreView® Side Defender™ radar is a small, rugged radar sensor designed by Preco® Electronics for side blind zone object detection in heavy duty over-the-road applications. When combined with an in-cab display, it alerts drivers to objects in the side blind zones of heavy trucks, busses, waste trucks, utility trucks, fire/ambulance and other heavy and medium-duty on-road vehicles. If provided vehicle speed over a J1939 CAN-bus interface, the Side Defender™ has intelligent modes of operation that help minimize false alerts due to fixed objects such as guardrails, while still providing reliable side object detection.



The sensor frequency band is legal throughout most of the world, but check with PRECO® Electronics or your country’s regulations before purchasing.

The Side Defender™ radar works in adverse weather conditions, has a wide operating temperature range, is sealed to meet IP69K, withstands high vibration and shock levels, and is maintenance free. Side Defender™ radar sensors include an 8-pin Deutsch connector pigtail as shown in Figure 1.

Using a frequency modulated transmit waveform (FMCW), the Side Defender™ radar measures radial range, speed and angle, reflectivity, and other parameters of multiple stationary and moving targets simultaneously. This radar sensor has a wide horizontal field of view up to +/-75°, optimized for side object detection in large trucks and busses. The horizontal field-of-view is approximately 40 feet along the sides and 10 feet wide as shown in Figure 2. This is designed to cover one traffic lane adjacent the truck, while looking forward and aft approximately 20 feet (6m).

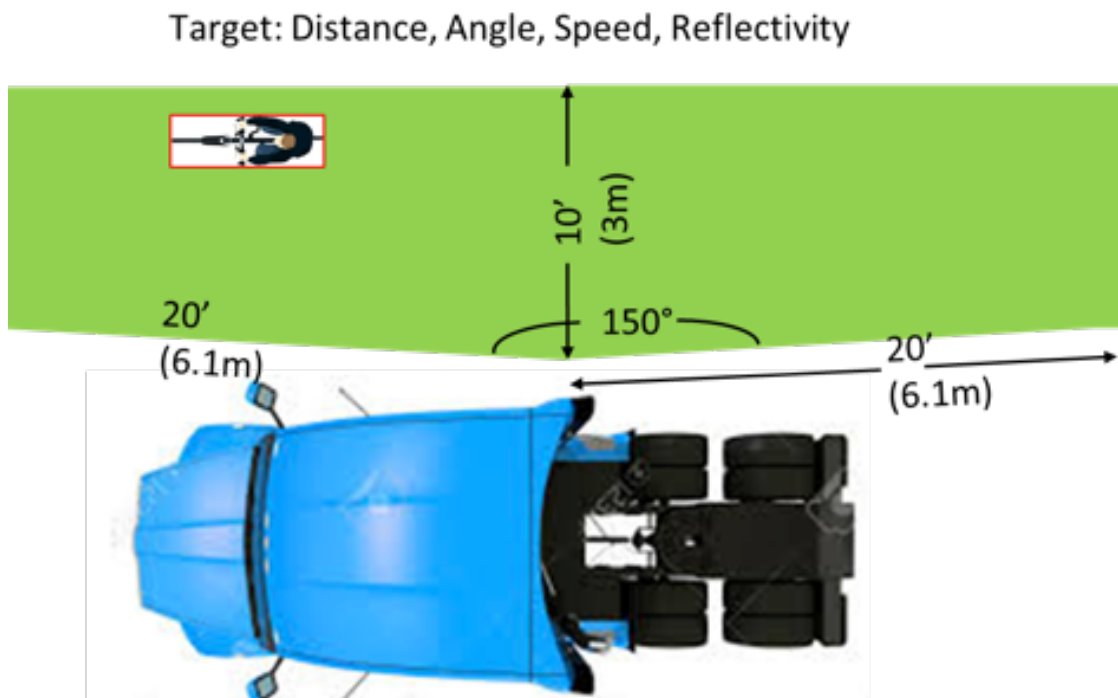

Figure 2. Horizontal Detection Zone

PreView® Side Defender™ radar can detect people, bicycles and other cars/trucks within the detection zone, providing a visual alert on the in-cab LED display, as well as an audible alert if the turn signal is deployed. Figure 3 shows the in-cab LED display.



The Side Defender™ radar sensor performance is not affected by other PreView® Side Defender™ radar or similar sensors operating in close proximity with each other.

Other Sensor Features

The Side Defender™ radar has a continuous Built-In-Self-Test (BIST) that notifies the operator display of sensor failure within a fraction of a second. This test functions by monitoring the transmit and receive performance as well as other internal operations.

The Side Defender™ radar can also determine if the face of the sensor is blocked with excessive ice, mud, or snow that is impeding proper operation. This blockage is then reported to the operator display.

Both the self-test and blockage detection features are important to fail-safe operation.

In-cab LED Display

Description

The in-cab display provides the vehicle operator with a visual indication of a detected object anytime the vehicle is operating. The display unit also contains a buzzer that provides an audible alert that only activates when the turn signal is energized, providing the operator with another cue that an object is being detected. The audible alert will only sound upon the first detection of an object while the turn signal is energized. The audible alert will not sound again until the turn signal is cycled.



Figure 3. In-cab LED Display Unit



Table 1. Operator Display Description

Item	Description
Status LED*	Illuminates green after power is applied to the system. Turns off anytime the detection LED is illuminated.
Detection LED*	Illuminates to alert operator to the presence of an object
Light Sensor*	Measures ambient light conditions allowing for Status and Detection LEDs' brightness to automatically adjust
Display Buzzer*	Sounds an audible tone to alert operator of obstacles

*Locations of LEDs and buzzer are different for left side kit.

Sensor Interfaces and Configuration

CAN-Bus Communication

The PreView® Side Defender™ radar has one CAN interface as specified in ISO 11898-2 (SAE J1939) with a transmission rate of 250 KBits/second. The sensor communicates with the PreView® In-cab LED display using this interface.

CAN-Bus Inputs

If the truck/bus speed is available via CAN-bus message, the Side Defender™ Radar can support certain J1939 vehicle speed messages (contact PRECO® Electronics for more information).

CAN-Bus Outputs

The Side Defender™ can provide object detection information and alerts as CAN-bus messages. This information can include distance, angle, velocity and signal strength of detected objects. Telematics or data logging of detection events can be supported via these CAN-bus outputs.

Turn Signal Input

The Side Defender™ radar requires a turn signal input for proper in-cab display operation. When the turn signal is active, the display audible alert will sound once when an object is detected. Refer to the system wiring diagram (Figure 4) for connection information.

Alert Output

The Side Defender™ radar supports an alarm output signal that can be used to provide additional operator alerts.



This output is an Active Low (switch to ground). One example use of this output is to drive an LED indicator in a side mirror when there is an object in the side blind zone. Contact PRECO® Electronics support for more information.

System Connections

Locate the vehicle's ignition power wire and connect to the red wire on the sensor harness. If it is necessary to extend the power wire on the supplied harness, use 20AWG wire as a minimum. Locate the vehicle's turn signal wire that is associated with the turn signal on the side on which the sensor is being installed, and connect to the blue wire. **(Be sure that the turn signal wire selected activates ONLY when the turn signal is active. On some trucks the daytime running lights and/or air brakes will activate the wires connected to the turn signal lamp).** Connect the black wire of the sensor harness to vehicle ground.



Figure 4. Wiring Connections

System Operation

The Side Defender™ radar system has two different modes of operation depending on if vehicle speed information is supplied to the system over the J1939 CAN bus.

No Vehicle Speed Available

If vehicle speed is NOT available to the system, the Side Defender™ system will detect and report all objects in the sensor field of view.

Vehicle Speed is Available

If vehicle speed is available to the system, the sensor is capable of filtering out stationary objects such as guardrails or concrete barriers, while still detecting moving objects in the blind zone based on the speed. This feature minimizes 'nuisance alerts' due to stationary objects in the detection zone, e.g. guardrails, signs, etc. This mode is optimized for on-highway blind zone collision mitigation due to lane change or merging.



At speeds above 10mph (16kph), the system ignores stationary objects.

At speeds below 10mph (16kph), the system will deactivate and not report on any objects.

Technical Data

The following figures provide the dimensions and specifications for the PreView® Side Defender Radar™ sensor.

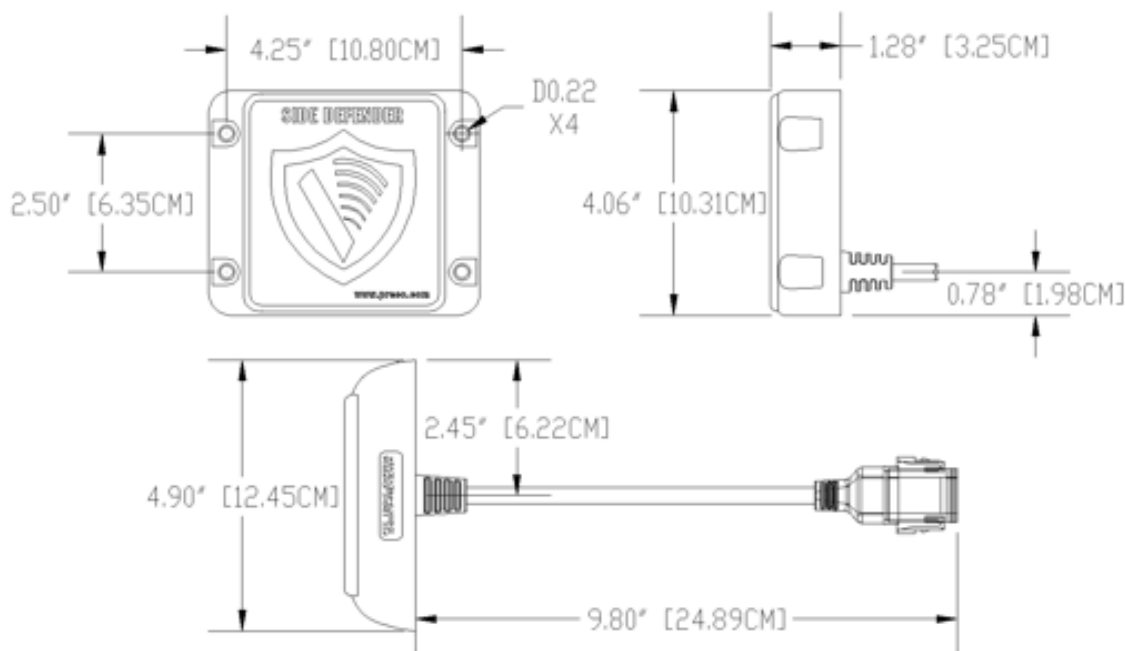
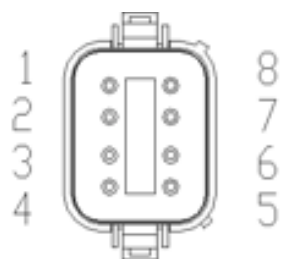

Figure 5. PreView® Side Defender™ Radar Dimensions

Sensor Connector Description

The Side Defender™ radar comes equipped with a pigtail harness terminated with a Deutsch DT connector. The pinout for the Deutsch connector is defined in Figure 6. The mate for this connector is a Deutsch DT04-08PA-CE01.





CONNECTOR END VIEW
DEUTSCH DT06-08SA-E008

CONNECTOR PIN OUT	
PIN	DESCRIPTION
1	BATTERY PWR INPUT(+)
2	GROUND
3	CAN HIGH
4	CAN LOW
5	DISPLAY PWR OUTPUT(+)
6	DISPLAY GND
7	N/C
8	TURN SIGNAL INPUT

Figure 6. Deutsch Connector Pin Out



Measuring Performance

Range:	Detection Zone as shown above – 10' (3m) x 40' (6m)
Range Accuracy:	0.3m
Azimuth Field of View:	±75 degrees (10dBsm target)
Elevation Field of View:	±10 degrees (10dBsm target)
Angle Accuracy:	±2° @ ±10° FOV, ±5 @ ±30° FOV, ±10 @ ±75° FOV
Velocity Range:	± 9 meters/sec (± 20 mph)
Velocity Accuracy:	0.2 meter/sec (0.5 mph)
Target Resolution:	1.4m for static targets, approaching 0.3 meters for dynamic targets
Cycle Time:	120ms (A CAN bus target message is provided in every cycle.)

Operating Conditions

Frequency:	24.00 – 24.25GHz
Power Supply:	9 – 33VDC, Reverse polarity and over-voltage protected
Current:	<0.5A
Operating Temperature:	-40°C to +85°C
Storage Temperature:	-55°C to +105°C
Shock:	50G
Vibration:	25G, random, all three axis
Protection Rating:	IP69K

Operating Modes

Target Detection Time:	300ms
Power On to Active Time:	300ms

Communications Interface

J1939 CAN Bus:	250Kbits/sec, un-terminated
LED Interface	Switch to ground, sink up to 1A, over current protected

Physical Characteristics

Sealing:	IP69K
Housing Material:	Polycarbonate radome
Dimensions:	4.90" (w) x 4.06" (h) x 1.28" (d) (12.4cm x 10.3cm x 3.25cm)
Weight:	1.0 lb (0.45kg).
Mounting:	Four 0.22" (5.6mm) diameter mounting holes.

Figure 7. Sensor Specifications



Regulatory Compliance

The PreView® Side Defender™ radar is compliant with the following countries/regions and their regulations as of the published date of this manual. The sensor may be compliant in other countries/regions. Please check your local regulations or contact PRECO® Electronics for support.

- United States - FCC- Part 15.249
 - FCCID: OXZJCKP2016
- Canada - RSS-210 Radio Standards Specification
- European Union - ETSI EN300 440-1 Electromagnetic Compatibility and Radio Spectrum Matters (ERM)
- Australia/New Zealand - AS/NZ 4268 Radio Equipment and Services – Short Range Devices



Installation

Sensor Mounting

The Side Defender™ radar mounting location is important for proper system operation. Ideally the sensor should be mounted on the side of the vehicle between 18" (45cm) and 24" (61cm) above the ground, as measured from level ground to the bottom of the sensor. The sensor face should be perpendicular to the ground with Side Defender™ text up and V logo pointing down. Select a location that will provide some protection from impact and debris while allowing an unobstructed view of the target hazard area. Refer to the Keep Out/Interference Zones listed below.

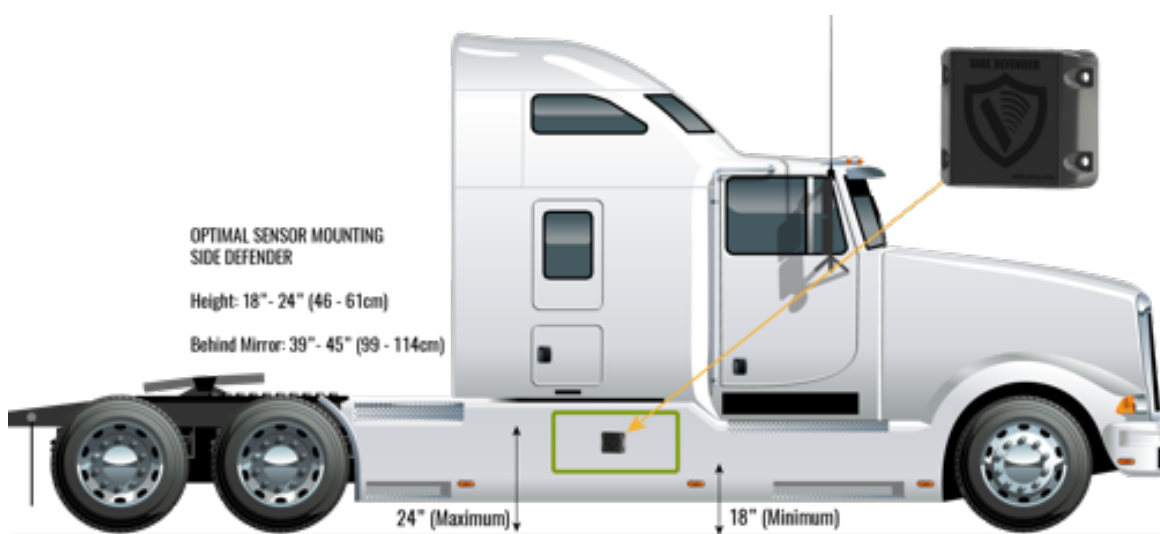

Figure 8. Sensor Position on Vehicle

Mounting Tolerances

For optimal performance, the vertical angle (up/down) tolerances are +5 degrees (up) and -2 degrees (down), and the horizontal angle (side/side) tolerance is +/- 5 degrees.



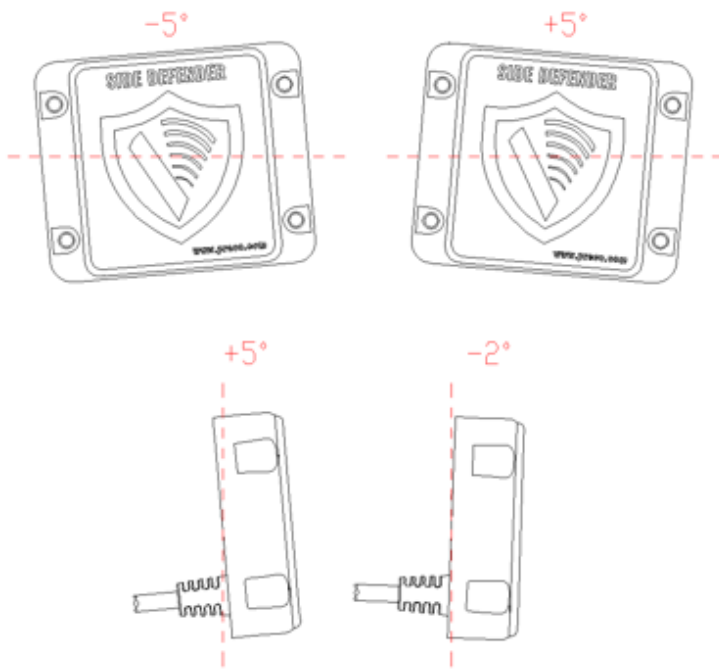
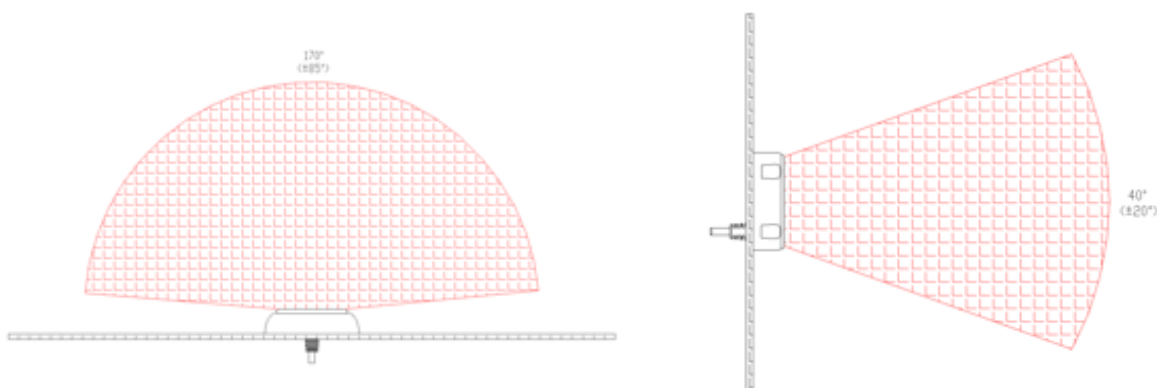

Figure 9. Vertical and Horizontal Angle Mounting Tolerances

The performance of the sensor can be negatively impacted if the sensor is angled down, causing false detection from the ground. Any time the sensor is not perpendicular to the ground, the performance should be tested.

Keep Out/Interference Zones

Metallic and any other strong radar reflecting objects must remain outside of the keep out zones defined in Figure 1. If radar reflecting objects reside within the keep out zones, testing must be performed to determine their influence on the sensor's performance.



Horizontal "Keep Out" Zone

Vertical "Keep Out" Zone

Figure 10. Keep Out Zones



The sensor's horizontal field of view is +/- 75 degrees and the vertical field of view is +/- 10 degrees. For optimal performance, the sensor should protrude beyond any other portion of the vehicle.

Important!

Before permanently installing the PreView® Side Defender™ Radar on the vehicle, verify that the selected sensor mounting location provides a clear detection zone. Take the vehicle to a clear area, temporarily attach the sensor in the proposed mounting location, apply power to the system, and verify that nothing is being detected.

Sensor Mounting Procedure

PRECO® Electronics supplies a 90 degree mounting bracket for the Side Defender™ radar. If the provided 90° bracket is not appropriate, please contact PRECO® Electronics

If mounting directly to the vehicle, follow the procedure outlined below.

1. Select the appropriate sensor mounting location in Figure 8.
2. The standard mounting configuration is with 'Side Defender™' text, as shown in Figure 1.
3. Using the bracket as a drill template, scribe position marks through the holes. Drill 1/4" (6mm) holes centered at the marks.
4. A 1.5" (40mm) diameter clearance hole may be required for the sensor connector and mating cable connector.
5. Secure the sensor to the vehicle with the four supplied #10-24 UNC button head screws, washers, and locking nuts or equivalent. Apply a maximum torque of 22 lb-inch (25 kg-cm) when securing the sensor.



Initial System Power Up and Test

Once the sensor and display are installed, wired, and connected, power should be applied to test correct system operation. When the system is operating correctly in an open field with no obstructions, the status LED indicating green will be the only light illuminated. If the detection LED (yellow) is lit, check for any vehicle obstruction which may be detected by the sensor. If possible, move the sensor so it is not detecting the object(s). If it is not possible to relocate the sensor, consult PRECO® Electronics.

If for some reason the system is malfunctioning, the status LED and detection LED will flash in unison and the buzzer will emit a short stuttering sound. Refer to the Troubleshooting section to determine the error and potential causes.

Once the system has been installed, the detection zone should be tested. This test should be performed with two people, one who remains in the cab (the operator), and one who walks through the sensor field to the side of the vehicle (the assistant). The operator engages the parking brake, depresses the vehicle brake, and turns on the ignition. The assistant then walks through the detection zone while the operator notes where the detection LED illuminates. Moving about the side of the vehicle and noting when the detection LED illuminates is the way to map an accurate detection zone.

Once the detection zone is determined, test the display buzzer operation. With nothing in the sensor detection area (green LED on), activate the appropriate turn signal. Have the assistant walk into the detection zone and verify that the display detection LED illuminates and the display buzzer emits a short tone. With the turn signal still activated, have the assistant walk out of the detection zone. Once the detection LED turns off, have the assistant walk back into the zone again. At this point, only the detection LED will illuminate. The display buzzer should not sound.



Troubleshooting

Display Status LED is not illuminated:

- Verify that DC power (9-33V) is applied to the sensor.
- Verify that the cable between the sensor and display is connected.

Display Status LED and Detection LED are flashing:

- The display is not communicating with the sensor. Check connection between display and sensor.

Detection LED is always illuminated when sensor is mounted:

- Verify the sensor is pointing outward from the vehicle in an open area with no obstructions. This may require removing the mounting screws and lifting the sensor out away from the side of the vehicle. If the detection LED is not active when moved away from the vehicle, but is active when mounted, then the sensors' mounting position will have to be moved.

Detection LED is on frequently when driving around and there is nothing in the detection zone:

- The sensor may be detecting a curb. Aim the sensor up about 2 degrees and check again. Do not aim the sensor up more than 5 degrees from perpendicular to ground.

Detection buzzer sounds when turn signal is not active:

- The harness turn signal wire is being set by other electronics, i.e., daytime running lights, air brakes, etc. Check turn signal wire connection.

The system is detecting stationary objects above 10mph (16kph):

- The sensor is not receiving speed messages over the CAN bus.



Object Detection Capability

The PreView® Side Defender™ radar system is a blind spot collision warning system designed to supplement other safety practices and/or devices. The machine operator is always the first line of defense when safely operating a vehicle. The person or owner responsible for the equipment must ensure that all operators understand the installation, operation, limitations and safe use of the system.

The Side Defender™ radar sensor can detect most objects within the detection zone. However, there are some instances where objects can go undetected. Obstacle size, shape, relative location, and composition are all factors determining if, when, and where an object is detected. The Side Defender™ Radar sensor operates by transmitting low power electromagnetic energy. Any energy that strikes an object reflects a certain amount of this energy back to the radar sensor of the Side Defender™ Radar. If the returned energy is of sufficient magnitude, it is used to indicate the presence of an object and determine the object's distance. While the radar sensor of the Side Defender™ Radar can resolve multiple objects, only the object closest to the vehicle is reported to the operator display since it represents the most significant collision threat.

The amount of energy returned is based on a few factors:

Size – a larger object usually reflects more energy than a smaller object.

Composition – a metal object typically reflects more energy than a non-metallic object. A metallic object at the edge of the maximum detection zone might be detected, whereas a wood object may not.

Scattering – a solid object reflects more energy than a non-solid object such as tree branches, gravel, bushes, etc.

Shape – complex shapes cause energy to be returned in a very non-uniform way. Very small variations or movement can change detection status.

Angle – an object that is flat-side perpendicular to the sensor will reflect more energy than an object at an angle. See below for an example of how angle can affect returned energy.



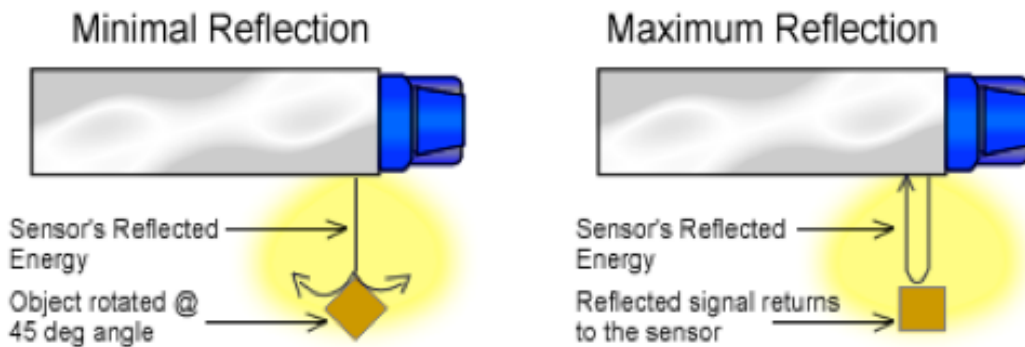

Figure 11. Object Reflection

Notes on Safety and Risks

Owner Responsibilities

The owner is responsible for ensuring that the device (and equipment) are used for their intended purpose, for the actions of the employees, for giving instruction to the employees, and for the operational safety of the equipment. The owner must understand the safety information for the device and the instructions given in the operating manual.

Lacking or incomplete training can lead to incorrect operation or improper usage. This may result in accidents involving serious injury or damage to property, assets, or the environment.

Always make sure that the device or equipment is not operated, serviced, or used by personnel who have not been properly trained to do so.



PreView® Side Defender™ Daily Maintenance

Detach this page and place with daily operator maintenance procedures.

Safety Message to Operators of Vehicles with PreView® Side Defender Radar Systems

1. The PreView® Side Defender™ Radar system is intended as an Object Detection System and should not be relied upon as your first line of defense for the safe operation of the vehicle. It should be used in conjunction with established safety programs and procedures to augment the safe operation of the vehicle, ground personnel, and adjacent property. Should the system become inoperative, it could jeopardize the safety or lives of those who depend on the system for safety.
2. Testing and inspection of the system in accordance with these instructions and a record of the results should be listed on the daily maintenance report. The units on operating vehicles must be tested each day prior to the vehicle's operation. Results of this test must be recorded in the maintenance log.
3. People operating this equipment **MUST** check for proper operation at the beginning of every shift or safety inspection period.
4. If a PreView® system is found to be inoperative upon test, the operator should flag or cover the driver display and mark as "inoperative" prior to the machine/vehicle operation.
5. People's lives depend on the proper installation of this product in conformance with these instructions. It is necessary to read, understand, and follow all instructions shipped with the product.
6. Failure to follow all safety precautions and instructions may result in property damage, serious injury, or death.
7. The PreView® Object Detection System is intended for commercial use. Proper installation requires a good understanding of vehicle/machine electrical systems and procedures, along with proficiency in the installation.
8. Store these instructions in a safe place and refer to them when maintaining and/or reinstalling the product.



Testing and Maintenance

NOTE: A walk-around test shall be performed every day to verify proper function of the system and to familiarize the operator with the zone of detection. More frequent inspections should be performed when:

- The vehicle is operating in a particularly dirty or harsh environment.
- The operator has reason to suspect the system has been damaged.

This test should be performed with two people, one who remains in the cab (the operator), and one who walks through the sensor detection field (the assistant). The below example illustrates the test for a backing sensor application. Use a similar procedure for front, side or multiple radar systems by confirming detection of each radar sensor in the operator display.

1. Clean the sensor face of any accumulation of dirt, mud, snow, ice, or debris.
2. Visually inspect the attached wiring and cable and verify that they are properly secured, not chafing or dangling free where they could become snagged and damaged. Inspect the Radar Sensor and Operator Display Module and verify that they are securely attached to the vehicle.
3. Set the park brakes, start the vehicle, depress and hold the vehicle brake.
4. Verify the green "POWER" light is illuminated on the in-cab display.
5. The area to the side of the vehicle should be clear of obstacles for a distance of 6 meters (20ft). If the display shows any indicator other than the green light then there are objects to the side of the vehicle that will interfere with the test. Move the vehicle to a clear area and proceed.
6. The assistant should move to approximately 2 meters (6ft) to the rear of the sensor in sight of the operator's mirrors. He should then walk toward the centerline of the sensor parallel to the vehicle, while the operator notes when the display detection LED illuminates, signifying the sensor has detected the object.
7. The assistant should continue walking through the area at the side of the vehicle while the operator notes the area that detection occurs.
8. Now face the sensor and walk from the center of the sensor straight back, away from the vehicle. When the display detection LED quits illuminating the detection limit has been reached.
9. Move halfway back towards the sensor and remain still for a few seconds, the display detection LED should stay lit, demonstrating the system's ability to detect a still object.
10. The assistant should walk the complete side of the vehicle noting the detection edges of the entire coverage area.
11. After the test the assistant needs to communicate to the operator the details on the detection zone.

For questions, call +1.844.787.2327 toll free in the USA. Call +1.208.323.1000 or send a fax request to +1.208.323.1034 for outside the USA, or submit an online request at www.preco.com/contact-us/
A safety specialist will respond within 24 hours.



Warranty Information

MANUFACTURER STANDARD LIMITED WARRANTY AND LIMITATION OF LIABILITY

Manufacturer warrants that on the Date of Purchase this Product will conform to Manufacturer's published specifications for the product, which are available from Manufacturer on request, and Manufacturer warrants that the product is free from defects in materials and workmanship. This Limited Warranty for the sensor extends for sixty (60) months from the date of shipment. Manufacturer will, at its option, repair or replace any product found by Manufacturer to be defective and subject to this Limited Warranty.

This Limited Warranty does not apply to parts or products that are misused; abused; modified; damaged by accident, fire or other hazard; improperly installed or operated; or not maintained in accordance with the maintenance procedures set forth in Manufacturer's Installation and Operating Instructions.

To obtain warranty service, you must ship the product(s) to the specified Manufacturer location within thirty (30) days from expiration of the warranty period. To obtain warranty service, call Customer Service at +1.866.977.7236 or +1.208.323.1000, or fax your request to +1.208.323.1034. Customer Service will issue warranty authorization and further instructions. You must prepay shipping charges and use the original shipping container or equivalent.

EXCLUSION OF OTHER WARRANTIES: MANUFACTURER MAKES NO OTHER WARRANTIES, EXPRESSED, IMPLIED OR STATUTORY. THE IMPLIED WARRANTIES FOR MERCHANTABILITY AND FITNESS FOR A PARTICULAR PURPOSE ARE HEREBY EXCLUDED AND SHALL NOT APPLY TO THE PRODUCT. BUYER'S SOLE AND EXCLUSIVE REMEDY IN CONTRACT, TORT OR UNDER ANY OTHER THEORY AGAINST MANUFACTURER RESPECTING THE PRODUCT AND ITS USE SHALL BE THE REPLACEMENT OR REPAIR OF THE PRODUCT AS DESCRIBED ABOVE.

LIMITATION OF LIABILITY: IN THE EVENT OF LIABILITY FOR DAMAGES ARISING OUT OF THIS LIMITED WARRANTY OR ANY OTHER CLAIM RELATED TO MANUFACTURER'S PRODUCTS, MANUFACTURER'S LIABILITY FOR DAMAGES SHALL BE LIMITED TO THE AMOUNT PAID FOR THE PRODUCT AT THE TIME OF ORIGINAL PURCHASE. IN NO EVENT SHALL MANUFACTURER BE LIABLE FOR LOST PROFITS, THE COST OF SUBSTITUTE EQUIPMENT OR LABOR, PROPERTY DAMAGE, OR OTHER SPECIAL, CONSEQUENTIAL OR INCIDENTAL DAMAGES BASED UPON ANY CLAIM FOR BREACH OF CONTRACT, NEGLIGENCE OR OTHER CLAIM, EVEN IF MANUFACTURER OR A MANUFACTURER'S REPRESENTATIVE HAS BEEN ADVISED OF THE POSSIBILITY OF SUCH DAMAGES.

Manufacturer shall have no further obligation or liability with respect to the product or its sale, operation and use, and Manufacturer neither assumes nor authorizes the assumption of any other obligation or liability in connection with such product.

This Limited Warranty gives you specific legal rights, and you may also have other legal rights, which vary, from state to state. Some states do not allow the exclusion or limitation of incidental or consequential damages, so the above exclusion or limitation may not apply to you.

Any oral statements or representations about the product, which may have been made by salesmen or Manufacturer representatives, do not constitute warranties. This Limited Warranty may not be amended, modified or enlarged, except by a written agreement signed by an authorized official of Manufacturer that expressly refers to this Limited Warranty.



