

LED INTERIOR LIGHTING

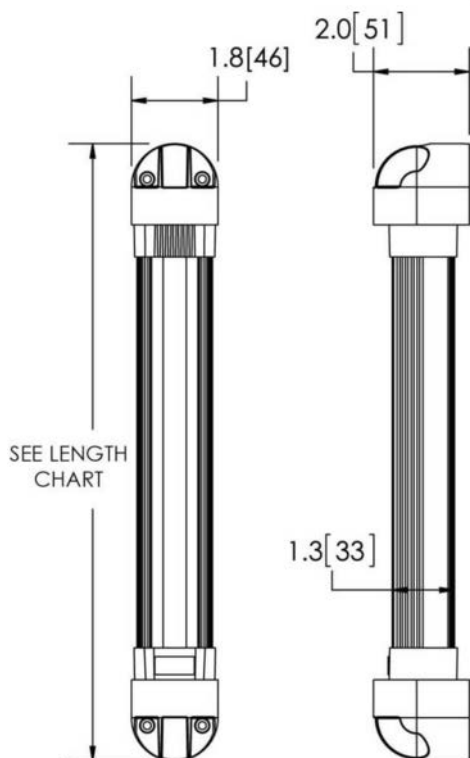

EW0700 Series



Description

Available in two length options these heavy-duty LED cargo/work area lights feature pivoting mounting feet that allow the angle of light output to be adjusted. Each unit has an integrated on/off switch, aluminum housing and operates on both 12 and 24V systems.

Features and Benefits

- Heavy-duty switched cargo / work area light
- Pivot-mounting foot provides adjustable lighting angles
- Surface mount (hardware included)
- Aluminum housing
- Approvals: CE, RoHS
- Warranty: 3 Years

Applications

Cargo/Work Area, Heavy-Duty

Tech Specs

Voltage	12-24V DC
Amps	0.5A (EW0700-13) 0.9A (EW0701-22)
eLumens	350 lm (EW0700-13) 1200 lm (EW0701-22)
rLumens	400 lm (EW0700-13) 1250 lm (EW0701-22)
LEDs	6 (EW0700-13) 12 (EW0701-22)
Warranty	3 Years
Approval	CE, RoHS
Length	13" (EW0700-13) 22" (EW0701-22)

Part No.	Description
EW0700-13	13" Length 12-24V DC 0.5A
EW0701-22	22" Length 12-24V DC 0.9A

Accessories	Description
EZ0120-PIR	PIR Motion Sensor – 100° cone, adjustable sensitivity (automatically activates light when human movement is detected)

Authorised Importer and Master Distributor

